

# ProDaylight 200 Air

# ProDaylight 400 Air

# ProBallast 200/400

## User's Guide EN

This user guide is available in other languages at [profoto.com/support](http://profoto.com/support)

CN – 其他语言版本的用户指南可从[profoto.com/cn/support](http://profoto.com/cn/support)下载

DE – Das Bedienungs-Handbuch is auch in anderen Sprachen verfügbar unter [profoto.com/de/support](http://profoto.com/de/support)

ES – Esta guía de usuario está disponible en otros idiomas en [profoto.com/support](http://profoto.com/support)

FR – Ce manuel d'utilisation est également disponible en d'autres langues sur [profoto.com/fr/support](http://profoto.com/fr/support)

IT – Questa guida per gli utenti è disponibile in altre lingue su [profoto.com/it/support](http://profoto.com/it/support)

JP – このユーザーガイドは[profoto.com/ja/support](http://profoto.com/ja/support)に他の言語でもご用意しています。

RU – Инструкция пользователя на других языках доступна на [profoto.com/ru/support](http://profoto.com/ru/support)





## Thank you for choosing Profoto

Thanks for showing us your confidence by investing in a ProDaylight Air unit. For more than four decades we have sought the perfect light. What pushes us is our conviction that we can offer even yet better tools for the most demanding photographers.

Before our products are shipped we have them pass an extensive and strict testing program. We check that each individual product comply with specified performance, quality and safety. For this reason our equipment is widely used in rental studios and rental houses worldwide, from Paris, London, Milan, New York and Tokyo to Cape Town.

### **Some photographers can tell just from seeing a picture, if Profoto equipment has been used.**

Professional photographers around the world have come to value Profoto's expertise in lighting and light-shaping. Our extensive range of Light Shaping Tools offers photographers unlimited possibilities for creating and adjusting their own light.

Every single reflector and accessory creates its special light and the unique Profoto focusing system offers you the possibility to create your own light with only a few different reflectors.

Enjoy your Profoto product!

# Safety instructions



## SAFETY PRECAUTIONS!

Read and follow all safety instructions below carefully to avoid injuries or damages! Make sure that Profoto Safety Instructions is always accompanied the equipment! Profoto products are intended for professional use! The equipment is only intended for indoor photographic or filming use. Do not place or use the equipment where it can be exposed to moisture, extreme electromagnetic fields or in areas with flammable gases or dust! Do not use the equipment in ambient temperature higher than +35 °C (+95 °F). Do not expose the equipment to dripping or splashing. Do not place any objects filled with liquids on or near the equipment. Do not expose the equipment to hasty temperature changes in humid conditions as this could lead to condensation water in the unit. Do not connect this equipment to equipment from other brands. Only use ballast, lamps and light shaping tools as specified by Profoto. Do not use lamp without supplied protective glass covers or protective grids. Do not stare directly at lamp while in operation. Minimum distance to flammable surfaces is 400 cm in front of the lamp. Limit exposure in front of the lamp if used at close distances. Glass covers shall be changed if they have become visibly damaged to such an extent that their effectiveness is impaired, for example by cracks or deep scratches. Lamps shall be changed if they are damaged or thermally deformed. When placing a lamp into the holder ensure not to touch the bulb with bare hands. Equipment must only be serviced, modified or repaired by authorized and competent service personnel!



## WARNING – Electrical Shock – High Voltage!

The equipment shall always be connected to grounded mains power supply outlet! Only use Profoto extension cables and mains cables! Do not open or disassemble ballast or lamp head! Equipment operates with high voltage. Disconnect lamp head cable between ballast and lamp head when changing bulb!



## Caution – Burn Hazard – Hot Parts!

Do not touch hot parts with bare fingers! Bulb, protective glass cover and certain metal parts emit strong heat when used! Reflector parts may reach a temperature of +200 °C (+392 °F). When the lamp has been in use, wait 10 minutes before removing the protective glass cover. Do not point lamp too close to persons. All lamps may on rare occasions explode and throw out hot particles!

### NOTICE

## NOTICE – Equipment Overheating Risk

Remove transport cap from lamp head before use! Do not obstruct ventilation by placing filters, diffusing materials, etc. over inlets and outlets of the equipment ventilation or directly over protective glass cover.

## Note about RF!

This equipment makes use of the radio spectrum and emits radio frequency energy. Proper care should be taken when the device is integrated in systems. Make sure that all specifications within this document are followed, especially those concerning operating temperature and supply voltage range. Make sure the device is operated according to local regulations. The frequency spectrum this device is using is shared with other users. Interference can not be ruled out.



## Final Disposal

Equipment contains electrical and electronic components that could be harmful to the environment. Equipment may be returned to Profoto distributors free of charge for recycling according to WEEE. Follow local legal requirements for separate disposal of waste, for instance WEEE directive for electrical and electronic equipment on the European market, when product life has ended!

# Table of Contents

Safety instructions .....	4
System description .....	7
Profoto Air .....	7
Nomenclature .....	8
Functionality .....	9
Metal halide lamp .....	9
Glass cover .....	9
Reflector .....	9
Cooling system .....	10
Built-in timer .....	10
ProBallast .....	11
Power supply .....	12
Frequency mode .....	12
Light intensity .....	12
Remote control .....	12
Operating instructions.....	13
Stand mounting .....	13
Remove protecting cap .....	13
Changing glass cover .....	13
Reflector mounting .....	14
Power connection .....	14
Radio settings.....	14
Frequency mode setting.....	15
Adjusting light intensity.....	15
Read out timer value.....	15
Changing settings in standby mode .....	15
Turn unit off .....	15
Remote control .....	16
Turn unit on/off .....	16
Light intensity setting .....	16
Maintenance.....	17
Changing lamp .....	17
Changing fuse .....	17
Trouble shooting .....	18
List of compatible Profoto Light Shaping Tools .....	19

Technical data .....	20
ProDaylight Air .....	20
ProBallast 200/400 .....	20
Warranty .....	21
Regulatory information .....	22
United States and Canada .....	22
Japan .....	23

## System description

ProDaylight Air is a metal halide based (HMI type) continuous light source. The powerful metal halide lamp provides daylight color temperature, which is ideal for many photo and video shoots.

The ProDaylight Air is designed for heavy-duty use. Its metal housing and all components are solid, reliable and withstand even the most demanding shooting situations.

The ProDaylight Air product family includes the following lamps:

- ProDaylight 200 Air
- ProDaylight 400 Air
- ProDaylight 800 Air

The ProDaylight 200 Air and ProDaylight 400 Air are powered from the ProBallast 200/400, a flicker-free multi-voltage electronic ballast. The ProBallast 200/400 is also used to control the ProDaylight 200 Air and ProDaylight 400 Air lamps.

As a professional photographer or videographer, you have your own special style and needs. Profoto's Light Shaping Tools – including the new line of Light Shaping Tools for Video Lights – fit perfectly with the ProDaylight 200 Air and ProDaylight 400 Air, enabling you to shape the light your own way.

For more information about the ProDaylight 800 Air, please refer to the ProDaylight 800 Air User's Guide.

### Profoto Air

Profoto Air is a system for convenient remote control of flash generators and studio lamps. The Profoto Air system is operating on one of eight selectable radio channels on the 2.4 GHz radio frequency band, for world wide use. Profoto Air allows control of your light from as far away as 300 m/1000 ft (free line of sight).

The Profoto Air radio system is fully integrated in the ProBallast 200/400, allowing wireless remote control of the ProDaylight 200 Air and ProDaylight 400 Air units.

### Profoto Air Remote

The Profoto Air Remote device offers remote control of your ProDaylight Air unit. The device controls practically an infinite number of ProDaylight Air units in up to six groups, either all at once in Master mode, or in individual groups.

# Nomenclature

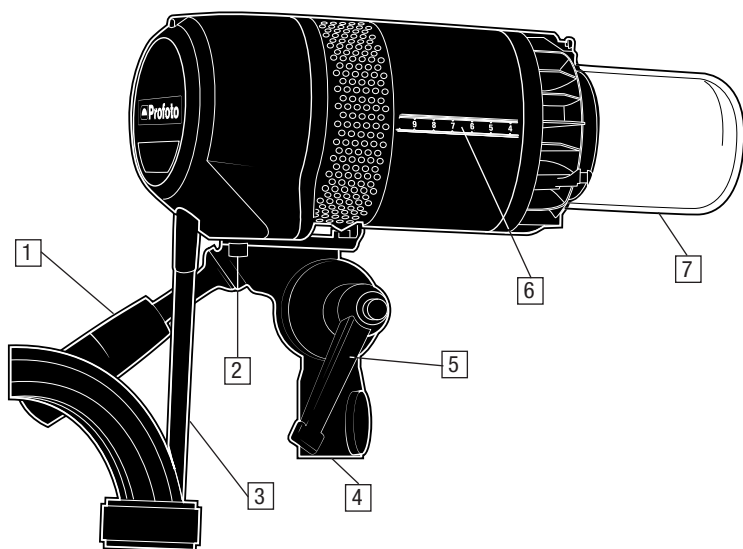

1. Handle
2. Bracket Screw
3. Lamp Cable
4. Stand Adapter
5. Locking Handle
6. Zoom Scale
7. Protective glass cover



# Functionality

## Metal halide lamp

The ProDaylight Air unit is equipped with a powerful metal halide lamp, providing daylight color temperature.



### SAFETY PRECAUTION!

*Profoto only uses UV-doped CSR-lamps, which emit a fraction of the hazardous UV radiation compared to classic HMI type lamps. Never use other types of lamps than the ones specified by Profoto.*

A cold metal halide lamp does not immediately begin producing its full light capacity. The warm up period can be a few minutes. During that time, the color of the light may vary.

If the ProDaylight Air unit is turned off, it takes about two minutes before the warm lamp can be turned on again. It is recommended to let the lamp run for at least **15 minutes** after turning it on, since turning the lamp on and off repeatedly considerably reduces the life time of the lamp.

## Glass cover

Metal halide lamps operate under high pressure and temperature, which calls for special safety measures. The ProDaylight Air unit is equipped with a protective glass cover that protects from lamp shattering and UV radiation. If the glass cover is not correctly mounted (see page 12), it is not possible to turn on the ProDaylight Air unit and “LAMP” is shown in the Display [F] on the ProBallast 200/400.



### SAFETY PRECAUTION!

*A damaged (cracked or scratched) glass cover must never be used! The level of UV protection provided by the glass cover is matched to the lamp type specified by Profoto. Only use Profoto specified lamps.*

The protective glass cover is available in different versions; with frosted and clear glass.

## Reflector

By mounting a reflector and placing it in different positions, using the Zoom Scale [6], several light characteristics can be created for each lighting purpose. The unique rubber collar fastening system provides secure and rapid handling of the reflectors, also when hot.

**Cooling system**

The ProDaylight Air unit is equipped with effective cooling, designed for optimal cooling without fan.

The cooling system includes automatic overheating protection. If the temperature of the ProDaylight Air unit exceeds maximum set levels, the ProDaylight Air unit will be turned off and "HOT" will be shown in the Display [F] on the ProBallast 200/400. This automatic protection will only interfere under extreme conditions, such as when the air vents are blocked.

**Built-in timer**

The ProDaylight Air unit has a built-in timer, which can be read out in standby mode. The timer feature is included to make it easier to keep track of lamp life.

# ProBallast

Metal halide lamps require an electronic ballast to deliver the proper voltage and current. The ProBallast 200/400 is a flicker-free electric ballast used to power the ProDaylight 200 Air and ProDaylight 400 Air. The ProBallast 200/400 has a passive cooling system for quiet operation.

The ProBallast 200/400 also includes a control panel for control of the ProDaylight 200 Air and ProDaylight 400 Air.

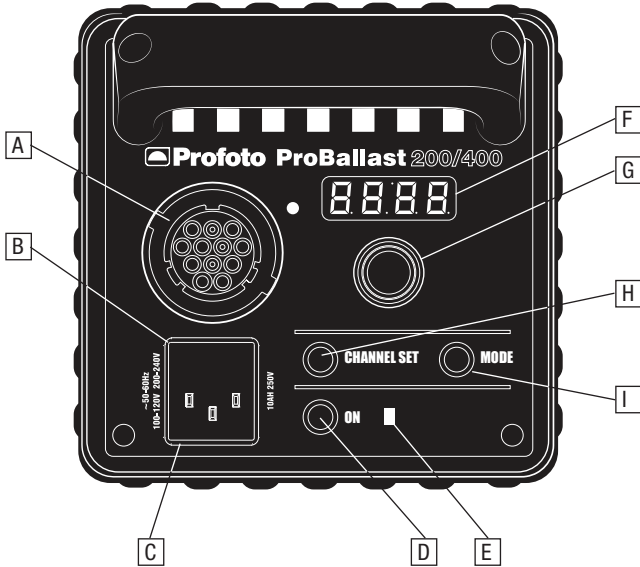

- A. Lamp Connector
- B. Fuse Holder
- C. Power Connector
- D. On/Off Button
- E. Power Indicator

- F. Display
- G. Setting Knob
- H. Channel Set Button
- I. Mode Button

## Power supply

The ProBallast 200/400 can be connected to 95-265 VAC, 50-60 Hz. The ballast automatically senses and adapts to the supplied voltage and frequency. The power supply fuses must be as specified in the section *Technical data*.

## Frequency mode

The frequency of the output voltage is switchable between 50 Hz (silent), 100 Hz (flicker free) and 300 Hz (high speed). A higher frequency will allow higher frame rates (fps) during video shoots without flicker. The Mode Button [I] is used to select the frequency mode setting.

## 12 Light intensity

The current light intensity of the ProDaylight Air is shown in the Display [F], in percent (%) of maximum light output. The Setting Knob [G] is used to adjust the light intensity, in 1% or 10% increments. The light intensity can be adjusted between 50 and 100%.

## Remote control

The Profoto Air radio system is fully integrated in the ProBallast 200/400, allowing wireless remote control of the ProDaylight Air unit.

With the Profoto Air Remote device, the ProDaylight Air unit can be turned on/off remotely and the light intensity can be adjusted. With the Profoto Studio Air software, multiple lighting setups including numerous continuous lights and flash units can be created and coordinated.

For more information about remote control, please refer to the User's Guides for Profoto Air Remote or Profoto Air USB/Profoto Studio Air.

# Operating instructions

## Stand mounting

1. Mount and fasten the ProDaylight Air unit on the stand using the locking knob on the Stand Adapter [4].
2. The unit can be directed upwards/downwards when the Locking Handle [5] is loosened. Fasten the Locking Handle [5] when the unit is correctly directed.

For alternative ways of mounting, the ProDaylight Air unit can be removed from the bracket by unscrewing the 5 mm hex socket Bracket Screw [2].

## Remove protecting cap

1. Unlock the clasp on the protecting cap.
2. Gently remove the protecting cap from the ProDaylight Air unit.

## Changing glass cover

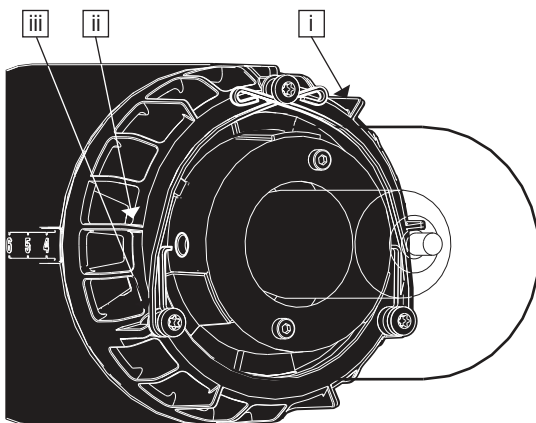

1. Ensure that the ProDaylight Air unit is turned off and that the Lamp Cable [3] is not connected.
2. If the ProDaylight Air unit has been in use, wait for the unit to cool down or use protective gloves.
3. Unlock the glass cover by pressing down the safety pins [i] and then pulling them out one by one.
4. Gently remove the glass cover and fit the new glass cover in place.
5. Make sure that the safety switch [ii] is pressed down and that both safety pins fit properly into the slots [iii] on each side of the glass cover.
6. Secure the glass cover by pressing the safety pins down and then pushing them one by one under the top screw.

## Reflector mounting

1. Unlock the clasp on the reflector.
2. Slide the reflector onto the ProDaylight Air unit. Use the Zoom Scale [6] to place the reflector in the desired position.
3. Secure the reflector by locking the clasp.

## Power connection

1. Connect the Lamp Cable [3] to the Lamp Connector [A] on the ProBallast 200/400 by aligning the white dots on the cable plug with the white dot on the ballast panel. Secure by turning the ring on the plug clockwise.

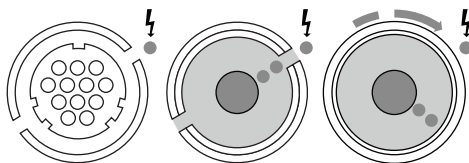

2. Connect the AC mains cable to the Power Connector [C] on the ProBallast 200/400 and to the mains power supply outlet.
3. The Power Indicator [E] will be red, indicating that the ballast is receiving power but is in standby mode.
4. Press the On/Off Button [D] to turn on the ProBallast 200/400 and the ProDaylight Air unit.
5. The Power Indicator [E] will now be green.

## Radio settings

1. Press the Channel Set Button [H]. The Display [F] will start flashing, showing the current radio channel number to the left and the radio group letter to the right, or "off" if the radio transceiver is switched off.
2. While the Display is flashing, turn the Setting Knob [G] to switch on/off the radio transceiver and to select radio channel number (**off, 1, 2, 3, 4, 5, 6, 7, 8**):
  - Turn the Setting Knob [G] clockwise to switch on the radio transceiver and increase the radio channel number.
  - Turn the Setting Knob [G] counter-clockwise to decrease the radio channel number and to switch off the radio transceiver.
3. While the Display is flashing, press and hold down and turn the Setting Knob [G] clockwise to increase the group letter (**A, B, C, D, E, F**) and counter-clockwise to decrease the letter.
4. Wait until the Display [F] stops flashing. (The Display will now show the light intensity.)

## Frequency mode setting

A higher frequency will allow higher frame rates (fps) during video shoots without flicker.

1. Press the Mode Button [I]. The Display [F] will show the current frequency mode setting.
2. Turn the Setting Knob [G] to change the frequency mode settings; 50 Hz (silent), 100 Hz (flicker free) and 300 Hz (high speed).

## Adjusting light intensity

Use the Setting Knob [G] to adjust the light intensity:

- Turn the Setting Knob [G] clockwise to increase the light intensity in 1% increments and counter-clockwise to decrease.
- Press and hold down the Setting Knob [G] and turn the knob clockwise to increase the energy in 10% increments and counter-clockwise to decrease.

## Read out timer value

To read out the timer value of the lamp head, the ProDaylight Air unit has to be connected to the ProBallast 200/400 and the ProBallast 200/400 must be in standby mode.

1. Press and hold the Setting Knob [G] for 1 second, then release the knob.
2. The Display [F] will show the timer value in hours. If no lamp head is connected, the Display [F] will show “----”.

## Changing settings in standby mode

All settings can be reached and changed in standby mode. A short press on the Setting Knob [G] will light up the Display [F] and make it possible to view and change settings.

## Turn unit off

1. Press the On/Off Button [D] to turn off the ProDaylight Air unit and the ProBallast 200/400.
2. The Power Indicator [E] on the ProBallast 200/400 will be red, indicating that the ballast is receiving power but is in standby mode.
3. Disconnect the AC mains cable on the ProBallast 200/400 device from mains power.

## Remote control

For remote control using Profoto Air Remote, the same radio channel and group have to be set on the ProBallast 200/400 and the Profoto Air device.

For remote control using Profoto Air USB and Profoto Studio Air, the same radio channel has to be set on the ProBallast 200/400 and in the Profoto Studio Air program.

For radio channel and group settings on the Profoto Air devices and the Profoto Studio Air program, please refer to the corresponding User's Guide.

### Turn unit on/off

Use the Head or Model Buttons (1) and (0) on the Profoto Air Remote device to turn the ProDaylightAir unit on and off.

### Light intensity setting

Use the Energy Buttons (+) and (-) on the Profoto Air Remote device to increase/decrease the light intensity:

- Press the Energy Button < 2 seconds to increase/decrease in 1% increments.
- Press the Energy Button > 2 seconds to increase/decrease in 10% increments.



# Maintenance

## Changing lamp

1. Ensure that the ProBallast 200/400 is turned off and that the Lamp Cable [3] is not connected.
2. If the ProDaylightAir unit has been in use, wait for the unit to cool down.
3. Unlock the glass cover by pressing the safety pins down and then pulling them out one by one, see figure on page 13.
4. Gently remove the glass cover.
5. Pull the lamp straight out of the socket. Always use protective gloves when doing this.
6. Insert a new modeling lamp, straight into the socket. Do not touch the lamp with bare hands.
7. Gently fit the glass cover in place.
8. Make sure that the safety switch is pressed down and that both safety pins fit properly into the slots on each side of the glass cover, see figure on page 13.
9. Secure the glass cover by pressing the safety pins down and then pushing them one by one under the top screw.

## Changing fuse

There are two exchangeable fuses in the ProBallast 200/400.

1. Disconnect the ProBallast 200/400 from AC mains power.
2. Pull out the Fuse Holder [B] and remove the old fuses.
3. Gently push the new fuses all the way into the Fuse Holder [B]. Only use fuses specified in section *Technical data*.
4. Gently push the Fuse Holder [B] in place.

## Trouble shooting

Symptom	Diagnose	Action
Power Indicator [E] not illuminated	Bad connection to the ballast or AC mains.	<ul style="list-style-type: none"> <li>• Check that the Lamp Cable [3] and the AC mains cable are correctly connected.</li> </ul>
	Internal fuse defect.	<ul style="list-style-type: none"> <li>• Check the fuses on the ProBallast 200/400. If the problem remains after replacing the fuses, contact your nearest Profoto service station.</li> </ul>
ProDaylight Air is not turned on when On/Off Button [D] is pressed and "LAMP" is shown in the Display [F].	A safety switch prevents the lamp from being turned on if the glass cover is not in place.	Fit the glass cover correctly in place, see instructions on page 13.
ProDaylight Air turns off automatically and "HOT" is shown in the Display [F].	The unit is overheated.	<ul style="list-style-type: none"> <li>• Ensure better ventilation.</li> <li>• Wait until the temperature decreases before the unit is turned on again.</li> <li>• If the problem remains please contact your nearest Profoto service station.</li> </ul>

## List of compatible Profoto Light Shaping Tools

The ProDaylight 200 Air and ProDaylight 400 Air can be used in combination with the following Profoto light shapers:

- HR Softboxes
- HR Lanterns, except HR Lantern 1.7' FLAT (Max 400W)
- ProCine reflector including lenses
- Softlight reflector
- Magnum reflector
- Zoom reflector
- Narrow beam reflector
- Narrow beam travel reflector
- Wide Zoom reflector
- Tele Zoom reflector
- ProTube
- Disc reflector
- Grid reflector
- ProFresnel Spot
- Profoto Giant reflectors (parabolic)
- Profoto Silver umbrellas (with ProCine reflector only)
- Profoto Translucent umbrellas (with ProCine reflector only)
- Profoto White umbrellas (with ProCine reflector only)
- Grids
- Standard softboxes
- Hardbox
- Snoot
- Grid and filter holder

The ProDaylight 200 Air and ProDaylight 400 Air are not recommended to be used with the following Profoto Light shapers:

- ProBox
- Spot Small
- ProGlobe
- Fresnel Small

# Technical data

## ProDaylight Air

	ProDaylight 200 Air	ProDaylight 400 Air
Wattage	200 W	400 W
Lamp type	GE CSR 200/SE/HR/UV-C	GE CSR 400/SE/HR/UV-C
Socket type	GZY9.5	GZZ9.5
Lamp life	200 hours	750 hours
Nominal color temperature	6000 K	5900 K
Dimensions	30 x 10 x 11 cm (11.8 x 3.9 x 4.3 in)	
Weight (incl. cable)	2.5 kg (5.5 lbs)	

## ProBallast 200/400

Lamp wattage	200/400 W
Input voltage/frequency	Automatic sensing: 95-265 VAC, 50/60 Hz
Fuse	10A, Fast acting type, 5 x 20 mm
Power factor correction (PFC)	Yes
Power factor	0.98
Dimming	50-100 %
Cooling	Passive
Lamp output	100 Hz (Flicker-free)
	300 Hz (High speed)
	50 Hz (Silent)
Dimensions	31.5 x 14.5 x 14.5 cm (12.4 x 5.7 x 5.7 in)
Weight	4.2 kg (9.3 lbs)

All data are to be considered as nominal and Profoto reserves the right make changes without further notice.

## Warranty

All Profoto products are individually tested before they leave the company and guaranteed for a period of two years with the exception of flash tubes, glass covers, modeling lamps, batteries and cables. Profoto is not responsible for technical malfunctions created by improper use or accessories made by other companies. If you have any technical problems please get in contact with an authorized Profoto service station. The Warranty is subject to and shall be interpreted in accordance with the law of the country where the product is purchased.

# Regulatory information

## United States and Canada

### F.C.C. and Industry Canada

Compliance Statement ( Part 15.19). This device complies with Part 15 of FCC rules and RSS-210 of Industry Canada. Operation is subject to the following two conditions:

- 1) this device may not cause harmful interference and,
- 2) this device must accept any interference received, including interference that may cause undesired operation.



### Warning (Part 15.21)

22

*Changes or modifications not expressly approved by the party responsible for compliance could void the user's authority to operate the equipment.*

Ce dispositif est conforme aux normes RSS-210 d'Industrie Canada. L'utilisation de ce dispositif est autorisée seulement aux conditions suivantes :

- 1) il ne doit pas produire de brouillage et
- 2) l'utilisateur du dispositif doit être prêt à accepter tout brouillage radioélectrique reçu, même si ce brouillage est susceptible de compromettre le fonctionnement du dispositif.

The term 'IC' before the certification/registration number only signifies that the Industry Canada technical specifications were met.

Les lettres 'IC' n'ont aucune autre signification ni aucun autre but que d'identifier ce qui suit comme le numéro de certification/d'enregistrement d'Industrie Canada.

### Profoto AB

**Transmitter / Receiver**

**MODEL: Profoto Air RMI**

**PRODUCT NO: PNZ1808-0000**

**FCC ID: W4G-RMI**

**IC: 8167A-RMI**

**Made in Sweden**

## Japan

The module has been granted modular approval for sale and operation in Japan.

特定無線設備の種類

Classification of specified radio equipment:

Article 2, Clause 1, Item 19

2.4 GHz Wide Band Low Power Data Communication

上記のとおり、電波法第38条の24第1項の規定に基づく認証を行ったものであることを証する。

This is to certify that the above-mentioned certification by type has been granted in accordance with the provisions of Article 38-24, Paragraph 1 of the Radio Law.

In order to comply with Japanese regulations the output power must be limited to 10 dBm and any user access to the RF-parts must be hindered by using:

- An enclosure that needs special tools to open
- An RF-shield that protects the transceiver, amplifier and VCO.

The product must be labelled with the following registration number:



®202WW08109201

Technical data and product information are subject to change without notice.

xxxxxx-x. Printed in Sweden.

**Profoto AB**

P.O. Box 1264

SE-172 65 Sundbyberg, SWEDEN

Visiting address:

Landsvägen 57, Sundbyberg

Phone +46 8 447 53 00

[info@profoto.com](mailto:info@profoto.com)

[www.profoto.com](http://www.profoto.com)



**Profoto®**  
The Light Shaping Company™