

# UM400

## Frequency-Agile UHF Belt-Pack Transmitter



**Featuring**  
**Digital Hybrid Wireless™ Technology**  
(US Patent Pending)

Fill in for your records:

Serial Number:

Purchase Date:



Thank you for selecting the Lectrosonics UM400 frequency agile, belt-pack transmitter. The UM400 combines over 80 years of engineering experience with the very latest components, in a design that addresses the most demanding professional applications.

The design of the UM400 was the direct result of numerous conversations with users, staging and touring companies and dealers across the US. The specific concerns and needs brought up in these conversations led directly to the development of the operational features offered on the UM400. Two hundred fifty six frequencies are user selectable in 100kHz steps to alleviate interference problems in traveling venues, and the low frequency roll-off is user adjustable to adapt to varying acoustic environments and preferences.

The UM400 is a rugged, machined aluminum package with a removable, spring loaded belt clip. The input section provides a correct input tap for virtually any microphone or line level audio source. Five volts of bias voltage is available to power electret mics with either positive or negative bias. Level indicating LEDs are provided on the control panel to make level settings quick and accurate, without having to view the receiver. The battery compartment accepts any 9 Volt alkaline battery and makes a positive connection via self-adjusting contacts. The antenna is a detachable, locking 1/4 wavelength flexible galvanized steel cable that connects to a 50 Ohm SMA port on the transmitter.

Only the UM400 transmitter is covered in this manual. Companion receivers are covered in separate manuals. The UM400 will operate with any 400 Series Lectrosonics receiver and a variety of analog receivers in the same frequency group.



# Table of Contents

<b>General Technical Description</b> .....	<b>6</b>
Introduction .....	6
Digital Hybrid Technology .....	6
UM400 Block Diagram .....	6
No Pre-Emphasis/De-Emphasis .....	7
Pilot Tone Squelch .....	7
Input Limiter .....	7
Wide-Band Deviation .....	7
Long Battery life .....	7
Frequency Agility .....	7
Antenna .....	7
<b>Controls and Functions</b> .....	<b>8</b>
Input Jack .....	8
Power ON/OFF Switch .....	8
Power On LED .....	8
Audio Level Control .....	8
Audio Level .....	8
Modulation LEDs .....	9
Antenna .....	9
Frequency Select Switches .....	9
Adjustable Low Frequency Roll-Off .....	9
Belt Clip .....	9
<b>Battery Installation</b> .....	<b>10</b>
<b>Operating Instructions</b> .....	<b>10</b>
Selecting the Compatibility Mode .....	10
Attaching a Microphone and Adjusting Gain .....	11
Operating Notes .....	11
Adjusting the Transmitter Frequency .....	11
<b>Microphone Cord Termination</b> .....	<b>12</b>
TA5F Connector Assembly .....	12
Mic Cord Stripping Instructions .....	12
<b>5-Pin Input Jack Wiring</b> .....	<b>13</b>
Input Jack Wiring Diagram .....	13
RF Bypassing .....	13
Line Level Signals .....	14
<b>Wiring Hookups for Different Sources</b> .....	<b>15</b>
<b>Replacement Parts and Accessories</b> .....	<b>16</b>
UHF Transmitter Antenna Specifications .....	16
<b>Troubleshooting</b> .....	<b>17</b>
<b>Specifications and Features</b> .....	<b>18</b>
<b>Service and Repair</b> .....	<b>19</b>
Returning Units for Repair .....	19

# General Technical Description

## Introduction

The 400 system uses 75 kHz wide deviation for an extremely high signal to noise ratio. The switching power supplies provide constant voltages to the transmitter circuits from the beginning (9.3 Volts) to the end (5.5 Volts) of battery life. The input amplifier uses an ultra low noise op amp for quiet operation. It is gain controlled with a wide range dual envelope input compressor which cleanly limits input signal peaks over 30 dB above full modulation.

## Digital Hybrid Technology

All wireless links suffer from channel noise to some degree, and all wireless microphone systems seek to minimize the impact of that noise on the desired signal. Conventional analog systems use compressors to improve the signal to noise ratio, at the cost of subtle artifacts (known as "pumping" and "breathing"). Wholly digital systems defeat the noise by sending the audio information in digital form, at the cost of some combination of power, bandwidth and resistance to interference.

The Lectrosonics Digital Hybrid system overcomes channel noise in a dramatically new way, digitally encoding the audio in the transmitter and decoding it in the receiver, yet still sending the encoded information via an analog FM wireless link. This proprietary algorithm is not a digital implementation of an analog

comparator but a technique which can be accomplished only in the digital domain, even though the inputs and outputs are analog signals. (As of this writing, the patent is still pending, so we cannot reveal detailed information about the algorithm at this time.)

Channel noise still has an impact on received signal quality and will eventually overwhelm the receiver. The Digital Hybrid simply encodes the signal to use a noisy channel as efficiently and robustly as possible, yielding audio performance that rivals that of wholly digital systems, without the power and bandwidth problems inherent in digital transmission. As always, these advantages come at a cost. The Digital Hybrid system requires fairly intensive digital processing in both the transmitter and the receiver. These processors cost money, take up space and consume power. The Digital Hybrid system also requires that the underlying RF link be of excellent quality, with better frequency response and distortion characteristics than that required by conventional systems.

Because it uses an analog FM link, the Digital Hybrid enjoys all the benefits of conventional FM wireless systems, such as excellent range, efficient use of RF spectrum, and long battery life. However, unlike conventional FM systems, the Digital Hybrid has done away with the analog compressor and its artifacts.

## UM400 Block Diagram

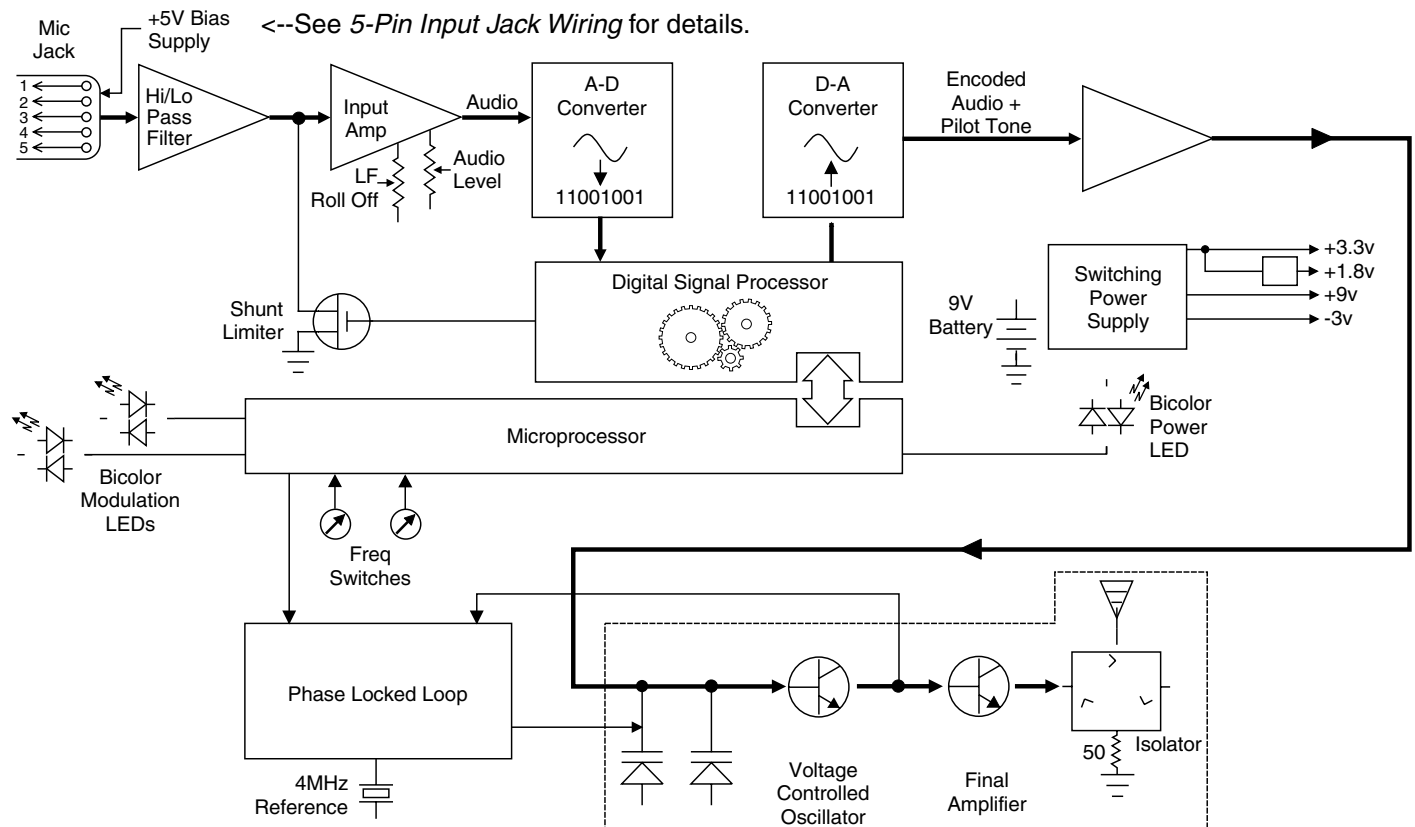

## No Pre-Emphasis/De-Emphasis

The signal to noise ratio of the 400 system is high enough to preclude the need for conventional pre-emphasis (HF boost) in the transmitter and de-emphasis (HF roll off) in the receiver. Pre-emphasis and de-emphasis in an FM radio system usually provides about a 10 dB improvement in the signal to noise ratio of the system, but the high frequency boost in the transmitter must be removed in a purely complementary manner or else the frequency response of the original audio signal will be altered.

Pre-emphasis can also cause distortion in the receiver. As this signal is passed through the IF filters in the receiver, distortion can be produced, most noticeably at full modulation. De-emphasis cannot be applied until the signal is converted into audio, so there is no way around this problem short of eliminating pre-emphasis altogether. Neither of these problems occur in the 400 system

## Pilot Tone Squelch

The 400 system uses one of 256 different ultrasonic tones between 25 and 32 kHz, that modulate the carrier to operate the receiver squelch. The pilot tone frequency is chosen according to which of the 256 channels has been selected by the frequency switch setting. The basic benefit of the pilot tone squelch system is that the receiver will remain muted until it receives the pilot tone from the matching transmitter, even if a strong RF signal is present on the carrier frequency of the system. The UM400 extends this concept even further by insuring that all transmitters in a system have different pilot tone frequencies so that even spurious RF from the wrong transmitters can't open the receiver squelch.

## Input Limiter

The 400 series transmitters employ a digitally-controlled analog audio limiter just before the analog-to-digital converter. The limiter has a range of more than 30 dB for excellent overload protection. A dual release envelope makes the limiter acoustically transparent while maintaining low distortion. It can be thought of as two limiters in series, connected as a fast attack and release limiter followed by a slow attack and release limiter. The limiter recovers quickly from brief transients, so that its action is hidden from the listener, but recovers slowly from sustained high levels, to both keep audio distortion low and preserve short term dynamic changes.

The audio level LEDs indicate limiter activity. The first red LED indicates that the limiter is active and that the

transmitter is fully modulated (audio level is between +0 and +10 dB). The second red LED indicates that the level is 10 dB or more into limiting. Occasional forays into the red are desirable for most applications, since the distortion introduced by the limiter is so minimal, and full modulation is thus assured. We strongly recommend setting the gain of the transmitter high enough so that the first red LED occasionally lights.

Generally speaking, some limiting is desirable in normal operation to improve the signal to noise ratio of the system. The limiting action is not audible and does not create distortion. A highly trained ear would hear only the compression of the peaks in the audio signal, which is desirable with most recorders and many sound reinforcement systems.

## Wide-Band Deviation

$\pm 75$  kHz deviation improves the capture ratio, signal to noise ratio and AM rejection of a wireless system dramatically, compared to the more commonly used  $\pm 15$  kHz deviation.

## Long Battery life

Switching power supplies throughout the design allow over five hours of operation using a single 9 VDC alkaline battery. (A 9 V lithium battery will provide over 10 hours of continuous operation.) The battery contacts are spring loaded to prevent "rattle" as the unit is handled.

## Frequency Agility

The transmitter section uses a synthesized, frequency selectable main oscillator. The frequency is extremely stable over a wide temperature range and over time.

Two rotary switches, located on the side panel of the unit, provide 256 frequencies in 100 kHz steps over a 25.5 MHz range. This alleviates carrier interference problems in mobile or traveling applications.

## Antenna

The antenna on the UM400 consists of a flexible 1/4 wavelength galvanized steel cable, detachable via an SMA connector. The impedance of this connector is 50 Ohms.

# Controls and Functions

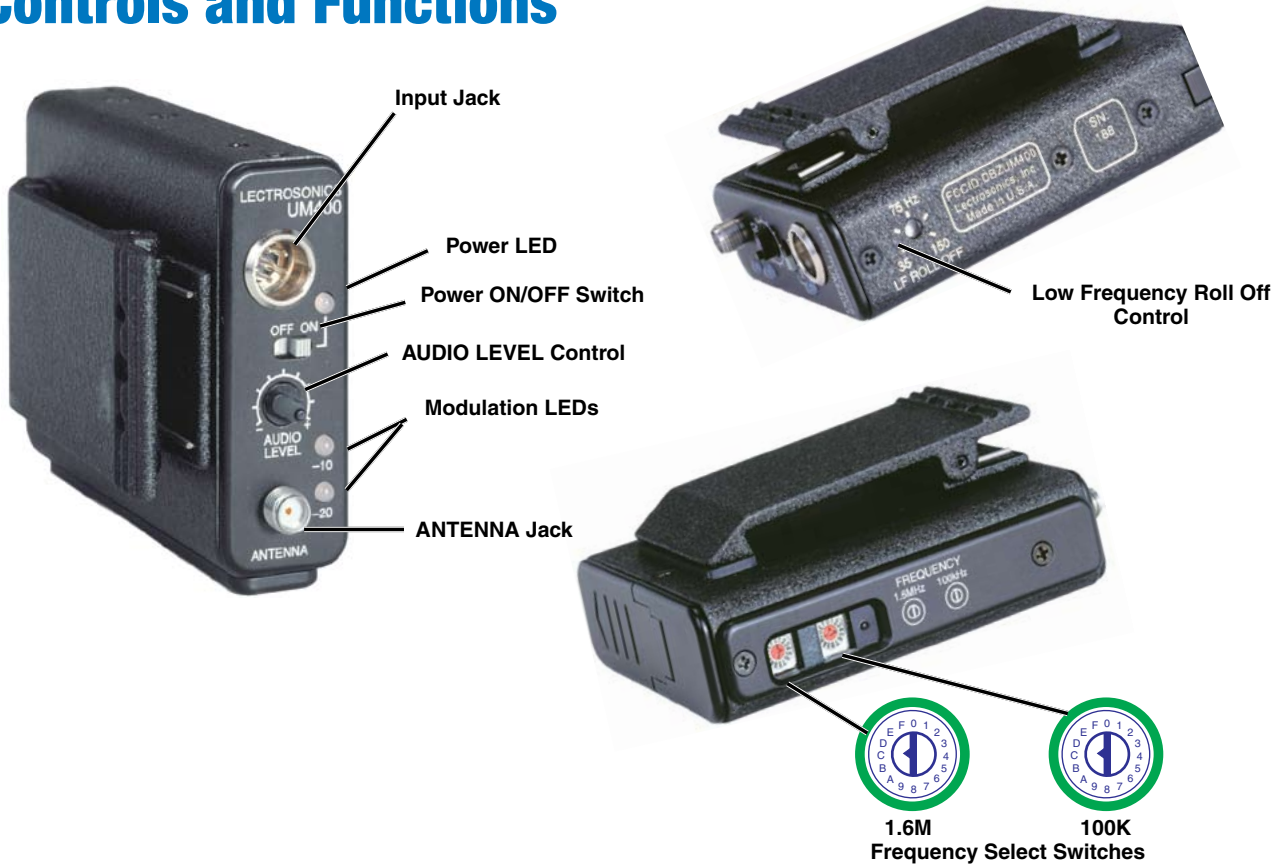

## Input Jack

The input on the UM400 accommodates virtually every lavalier, hand-held or shotgun microphone available. Different line level signals can also be accommodated. (See Line Level Signals and Transmitter 5-Pin Input Jack Wiring.)

## Power ON/OFF Switch

Turns the transmitter on and off. Even when the switch is turned off or on abruptly, the pilot tone muting system prevents “thumps” or transients from occurring.

## Power On LED

The Power LED glows green when the battery is good and the transmitter is turned on. The LED will glow yellow/orange as the battery voltage drops and finally glows red when there are about 30 minutes of operation left (when using the recommended alkaline battery). The LED blinks red when there are only a few minutes of life left.

**NOTE:** A NiMH battery will give little or no warning when it is depleted. If you wish to use NiMH batteries in the UM400, we recommend trying fully charged batteries in the unit, noting the length of time that the batteries will run the unit and in the future use somewhat less than that time to determine when the battery needs to be replaced.

A weak battery will sometimes light the Power LED to the “good” green indication immediately after being put in the unit, but will quickly discharge to the point where the LED will go red or shut down (just like a flashlight with “dead” batteries). If the lamp fails to light, the battery should be replaced.

## Audio Level Control

The front panel AUDIO LEVEL Control is used to adjust the incoming audio input level for proper modulation.

## Audio Level

Used to adjust the audio input level for the proper modulation.



## Modulation LEDs

The Modulation LEDs provide a visual indication of the input audio signal level from the microphone. These two bicolor LEDs can glow either red or green to indicate modulation levels.

Signal Level	-20 LED	-10 LED
Less than -20 dB	Off	Off
-20 dB to -10 dB	Green	Off
-10 dB to +0 dB	Green	Green
+0 dB to +10 dB	Red	Green
Greater than +10 dB	Red	Red

The Modulation LEDs are also used to indicate the Compatibility Mode when the transmitter is initially turned on. The Modulation LEDs will blink simultaneously:

- Once for 100 Series mode
- Two times for 200 Series mode
- Three times for mode 3
- Four times for Digital Hybrid Wireless™ or 400 Series mode
- Five times for IFB mode\*
- Six times for mode 6

Modes 3 and 6 provide compatibility with other manufacturer's receivers - contact the factory for details.

## Antenna

The flexible galvanized steel cable antenna supplied with the transmitter is cut to 1/4 wavelength of the center of the frequency block (the frequency range) of the transmitter. It is removable via an SMA connector. The SMA connector is a 50 Ohm RF port which can also be connected directly to test equipment. Replacement antennas are available in pre-cut lengths for specific frequency blocks, or as a kit with instructions to cut the antenna for any frequency block.

## Frequency Select Switches

Two 16-position rotary switches adjust the center frequency of the carrier. The 1.6M is a coarse adjustment and the 100K is the fine adjustment.

## Adjustable Low Frequency Roll-Off

A 18dB per octave low frequency roll-off is provided in the audio section, with the -3dB point adjustable from 35Hz to 150Hz. The actual roll-off frequency will vary somewhat according to the low frequency response of the mic capsule being used.

The low frequency roll-off control is used to remove subsonic (or very low frequency) audio, often produced by air conditioning systems, automobile traffic and other sources from the audio signal. Excessive low frequency content in the audio input can cause a variety of audio problems including driving the transmitter into limiting. In sound reinforcement systems, as one instance,

excessive low frequency content can cause excessive power amplifier drain or even damage to loudspeaker systems. By rotating the control clockwise, the hinge point of the roll-off is increased to reduce the level of low frequencies. In controlled situations, such as a motion picture production set indoors where environmental noise is minimal, the control can be rotated counter-clockwise to permit low frequency audio to be captured.

## Belt Clip

The belt clip may be removed for special applications by removing one screw.

**WARNING: Use ONLY the screw that is supplied**

The circuitry is tightly packed into this unit. A longer screw will permanently damage the transmitter! Use only Lectrosonics PN:28528 which is a Phillips head, 4-40 x 3/16", FL100 screw.

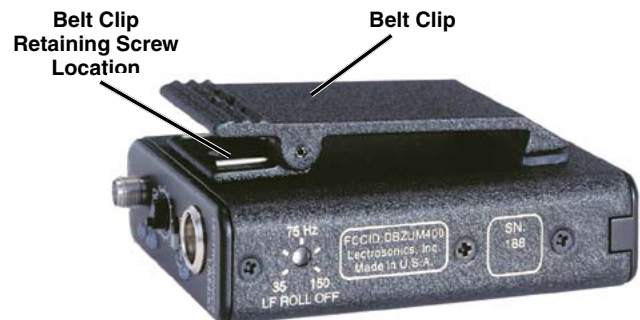

\*Not available on earlier units.

## Battery Installation

The transmitter is powered by a standard alkaline or lithium 9 Volt battery. It is important that you use ONLY an ALKALINE or LITHIUM battery for longest life. Standard zinc-carbon batteries marked “**heavy-duty**” or “**long-lasting**” are not adequate. Ni-cad rechargeable batteries will only provide 1.5 hours of operation, or less, and will run down quite abruptly. Alkaline batteries provide over 5 hours of operation. Lithium batteries can be used to provide up to 16 hours. Care should be taken not to leave a fully discharged lithium battery in the transmitter, as swelling of the battery can make it difficult to remove from the compartment. The battery status circuitry is designed for the voltage drop over the life of alkaline batteries.

To open the battery compartment, press outward on the cover door in the direction of the arrow as shown in the drawing. Only firm, sliding pressure is needed to open and close the battery door. Swing the door open and take note of the polarity marked inside showing the location of the positive (+) and negative (-) terminals. You can see the large and small contact holes inside the battery compartment with the door open.

Insert the battery correctly and close the cover by pressing the door closed and across, reversing the opening procedure illustrated above. If the battery is inserted incorrectly, the door will not close. Do not force the door

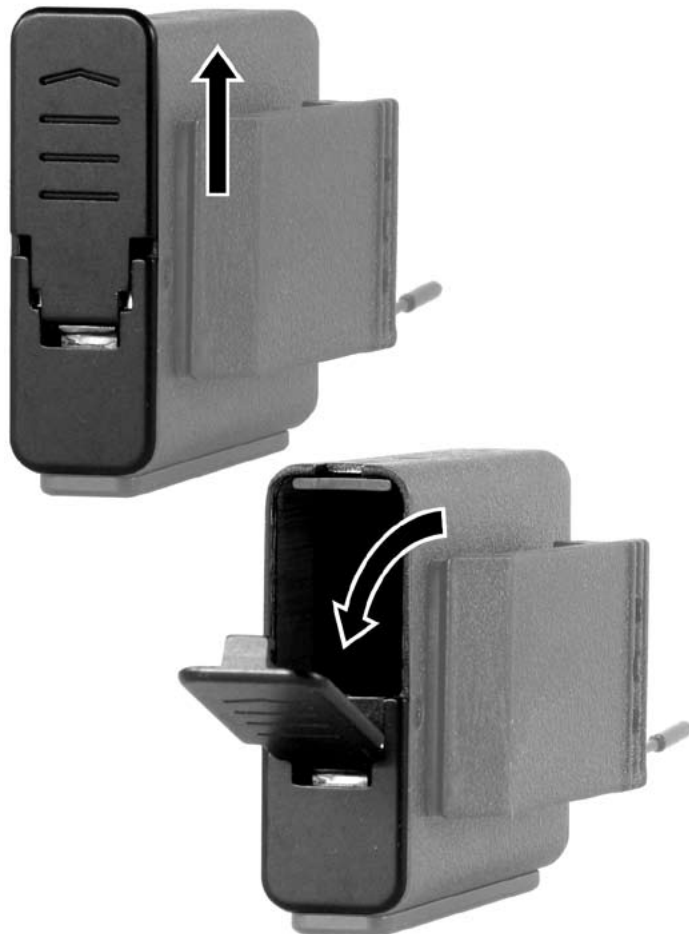

## Operating Instructions

### Selecting the Compatibility Mode

All units with serial number 601 and up are capable of working with Lectrosonics 400 Series Digital Hybrid Wireless™, 200 Series analog, 100 Series analog and some non-Lectrosonics analog wireless receivers (contact the factory for details). The transmitter must be set to the operating mode of the matching receiver, which is easily done using only the supplied screwdriver and a battery.

**NOTE:** The unit is supplied from the factory as a 400 series transmitter.

- 1) Ensure the battery is good.
- 2) Turn off the transmitter.
- 3) With a small screwdriver (one is included with your unit), set the Frequency Select Switches to CC. (for Change, Change).
- 4) Power up the unit briefly – just long enough for the LED's to light up and then turn it off.
- 5) Change the Frequency Select Switches to one of the following settings:
  - To set Lectrosonics 100 Series mode: set switches to 1,1
  - To set Lectrosonics 200 Series mode: set switches to 2,2
  - To set mode 3: set switches to 3,3 (contact the factory for details)
  - To set Lectro 400 Series mode: set switches to 4,4
  - To set IFB mode: set switches to 5,5\*
  - To set Mode 6: set switches to 6,6
- 6) Turn the unit on, wait a couple of seconds and turn off again.
- 7) Change the Frequency Select Switches to 0,0.
- 8) Turn on the transmitter to complete the operation.

The LEDs will blink to indicate the selected compatibility mode. Immediately after power up, all LEDs will blink together red, then green, followed by the audio level LEDs (-20 and -10) blinking to indicate the mode.

The -20 and -10 LEDs will blink:

- **Once for 100 Series mode**
- **Two times for 200 Series mode**
- **Three times for some other receivers**
- **Four times for 400 Series mode**
- **Five times for IFB mode\***
- **Six times for Mode 6**

At power up, the transmitter will confirm the current compatibility mode with the number of blinks listed here. This setting will remain the same until you reset it with the procedure listed above.

*\*Not available on earlier units.*

## Attaching a Microphone and Adjusting Gain

- 1) Ensure the battery is in good condition.
- 2) Insert the microphone plug into the input jack, aligning the pins; be sure that the connector locks.
- 3) Attach the antenna to the SMA connector on the top of the transmitter.
- 4) Mute the associated receiver's audio output.
- 5) Turn on the transmitter.
- 6) Position the microphone in the location you will use in actual operation. While speaking or singing at the same voice level that will actually be used, observe the Modulation LEDs. Adjust the AUDIO LEVEL control until the -20 dB LED glows green with occasional red flickers and -10 dB glows green. This will set the gain of your transmitter to between +0 dB and +10 dB modulation. (See chart below.)

Signal Level	-20 LED	-10 LED
Less than -20 dB	Off	Off
-20 dB to -10 dB	Green	Off
-10 dB to +0 dB	Green	Green
+0 dB to +10 dB	Red	Green
Greater than +10 dB	Red	Red

- 7) Once the gain has been adjusted, the audio system audio can be turned on to make level adjustments in the main audio system.

**NOTE:** The transmitter Audio Level Control should not be used to control the volume of your sound system or recorder levels. This gain adjustment matches the transmitter gain with the user's voice level and microphone positioning.

## Operating Notes

If the audio level is too high — both LEDs will blink red frequently or glow a steady red. This condition may reduce the dynamic range of the audio signal.

If the audio level is too low — neither LED will glow, or only the -20 LED will glow green. This condition may cause hiss and noise in the audio.

Different voices will usually require different settings of the AUDIO LEVEL control, so check this adjustment as each new person uses the system. If several different people will be using the transmitter and there is not time to make the adjustment for each individual, adjust it for the loudest voice.

## Adjusting the Transmitter Frequency

If you are experiencing interference from another signal on your frequency, you may want to change the operating frequency of your system. The left switch changes the operating frequency by 1.6 MHz per step and the right switch changes it 100 kHz per step. Start by changing the operating frequency in 100 kHz increments to find a clear channel. If it is not possible to find a clear channel using the 100 kHz switch, return it to its original position and change the 1.6 MHz switch by one click then try the 100 kHz switch again.

To gain access to these switches, slide the access door sideways with a fingernail.

With the 400 Series receivers, a front panel LCD character display will indicate the correct transmitter switch settings.



# Microphone Cord Termination

*Caution: When wiring the connector, do not use the connector body for any electrical connections. A common mistake is to use the connector body as an audio ground. The connector body is already used as an RF ground on VHF models and no other use is permitted.*

## TA5F Connector Assembly

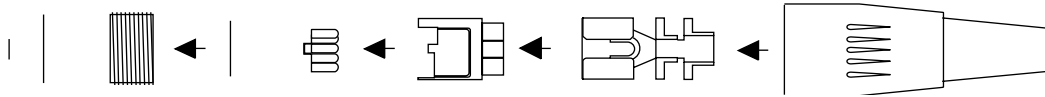

## Mic Cord Stripping Instructions

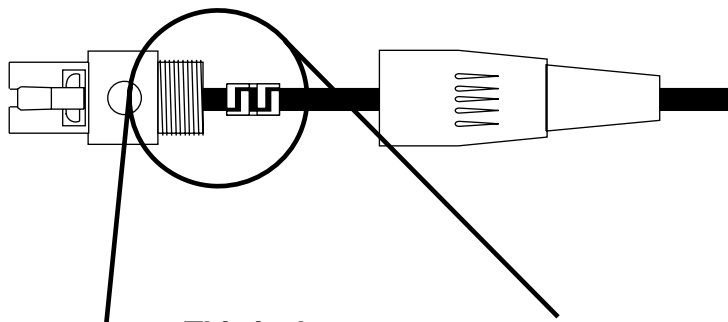
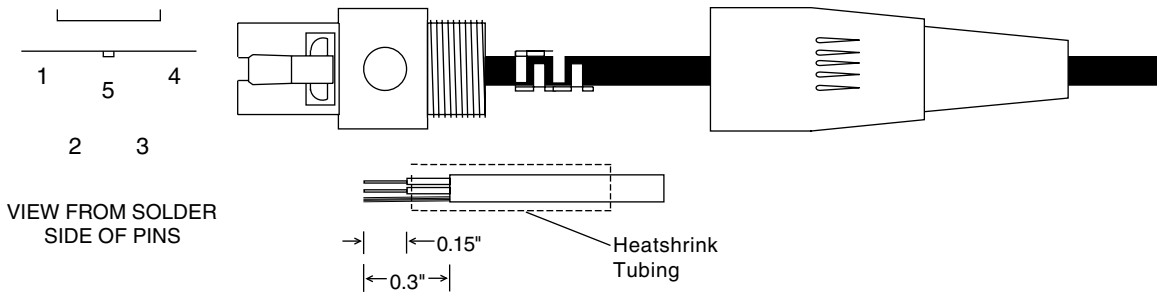

**Caution!**

Do not allow the shield wire to touch any metal part of the connector shell. The shield wire is the antenna on VHF models and poor operating range will result.

**This is the correct way.**

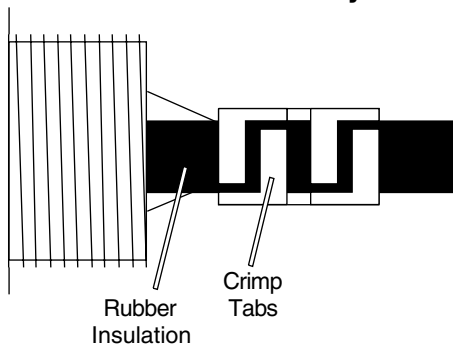

**Don't do it this way!**

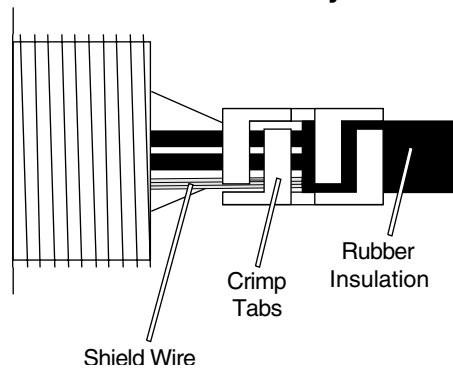

**NOTE:** This termination is required on VHF transmitters and will still work fine on UHF transmitters.

# 5-Pin Input Jack Wiring

The wiring diagrams shown on the next page represent the basic wiring necessary for the most common types of microphones and other audio inputs. Some microphones may require extra jumpers or a slight variation on the diagrams shown.

**Caution:** When wiring the connector, do not use the connector body for any electrical connections. A common mistake is to use the connector body as an audio ground. The connector body is already used as an RF ground on VHF models and no other use is permitted.

It's virtually impossible to keep completely up to date on changes that other manufacturers make to their products. It is possible that you may encounter a microphone that differs from these instructions. If this occurs please call our toll-free number listed on page 15 of this instruction manual. Our service department can answer your questions regarding microphone compatibility.

When used on a wireless transmitter, the microphone element is in the proximity of the RF coming from the transmitter. The nature of electret microphones makes them sensitive to RF, which can cause problems with the microphone/transmitter compatibility. If the electret microphone is not designed properly for use with wireless transmitters, it may be necessary to install a chip capacitor in the mic capsule or connector to block the RF from entering the electret capsule. This modification is shown on the next page.

VHF transmitters use the shield of the microphone cord as the antenna. This transmitter uses a 1/4 wave flexible wire to radiate the RF signal. There is really not much difference between these two approaches, with respect to the effect of the RF on the microphone cap-

sule. Even in transmitters that utilize a "dangling wire," the microphone is still part of the "ground plane" and is therefore still in the antenna circuit.

- PIN 1** Shield (ground) for positive biased electret lavalier microphones. Bias voltage source for negative biased electret lavalier microphones. Shield (ground) for dynamic microphones and line level inputs.
- PIN 2** Shield (ground) for negative biased electret lavalier microphones. Bias voltage source for positive biased electret lavalier microphones.
- PIN 3** Low impedance microphone level input for dynamic microphones. Also accepts hand-held electret microphones provided the microphone has its own built-in battery.
- PIN 4** 4K Ohm source load for non-Lectrosonics electret microphones. Use in conjunction with other pins to provide attenuation of high level input signals.
- PIN 5** High impedance, line level input for tape decks, mixer outputs, musical instruments, etc.

## RF Bypassing

Some mics require RF protection to keep the radio signal from affecting the capsule, even though the transmitter input circuitry is already RF bypassed (see schematic diagram).

If the mic is wired as directed, and you are having difficulty with squealing, high noise, or poor frequency response; RF is likely to be the cause.

## Input Jack Wiring Diagram

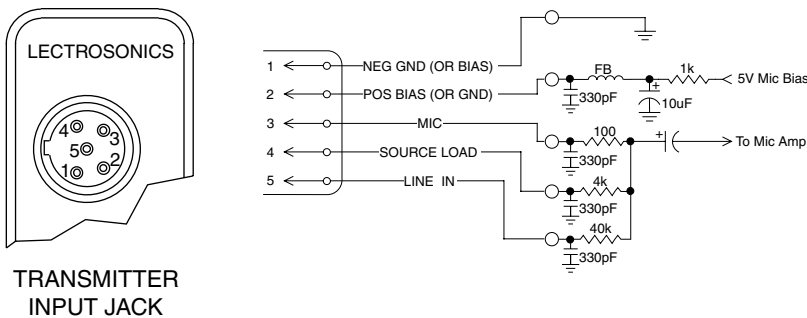

The best RF protection is accomplished by installing RF bypass capacitors at the mic capsule. If this is not possible, or if you are still having problems, capacitors can be installed on the mic pins inside the TA5F connector housing.

Install the capacitors as follows: Use 330 pF capacitors. Capacitors are available from Lectrosonics. Please specify the part number for the desired lead style.

Leaded capacitors: P/N 15117

Leadless capacitors: P/N SCC330P

All Lectrosonics lavalier mics are already bypassed and do not need any additional capacitors installed for proper operation.

**Caution:** When wiring the connector, do not use the connector body for any electrical connections. A common mistake is to use the connector body as an audio ground. The connector body is already used as an RF ground on VHF models and no other uses permitted.

### Line Level Signals

The normal hookup for line level signals is: Signal Hot to pin 5, Signal Gnd to pin 1, pin 4 jumped to pin 1, and pin 3 jumped to pin 1. This gives a 40dB attenuator that allows signal levels much higher than 3V to be applied without limiting.

If more headroom is needed, insert a 100k resistor in series with pin 5. Put this resistor inside the TA5F connector to minimize noise pickup.

If lower than normal line levels (less than 1V) are expected, use this hookup: Signal Hot to pin 5, Signal Gnd to pin 1, and pin 4 jumpered to pin 1. This provides a 20dB attenuator allowing signals as high as 3V to be applied without limiting.

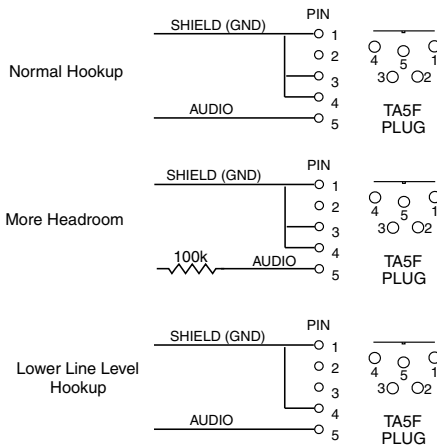
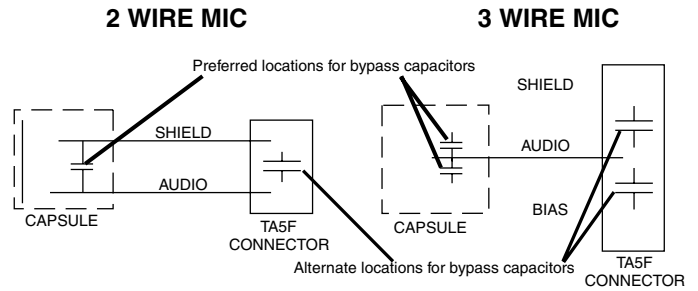

# Wiring Hookups for Different Sources

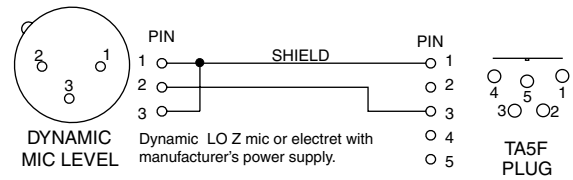
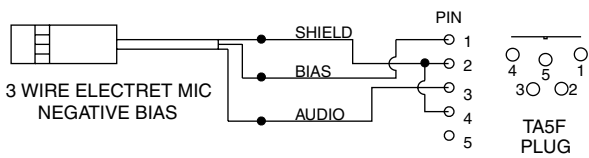
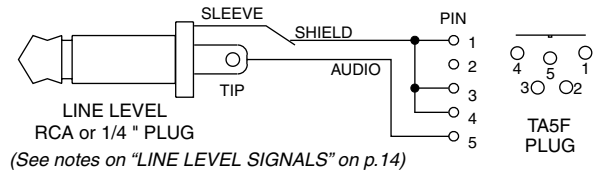
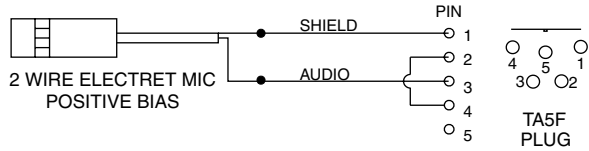
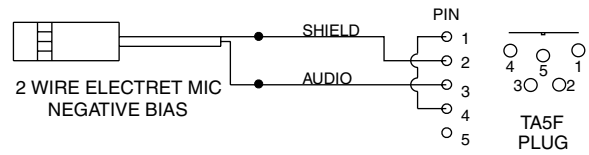
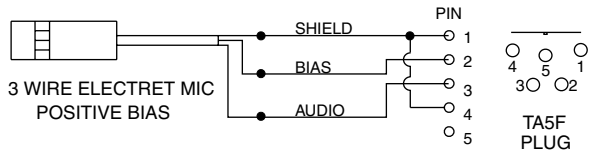

# Replacement Parts and Accessories

Item	Model/Part Number
Replacement wire belt clip	Lectrosonics #BCWire
Replacement whip antenna	Lectrosonics AMM (xx) - specify frequency block (xx)

## UHF Transmitter Antenna Specifications

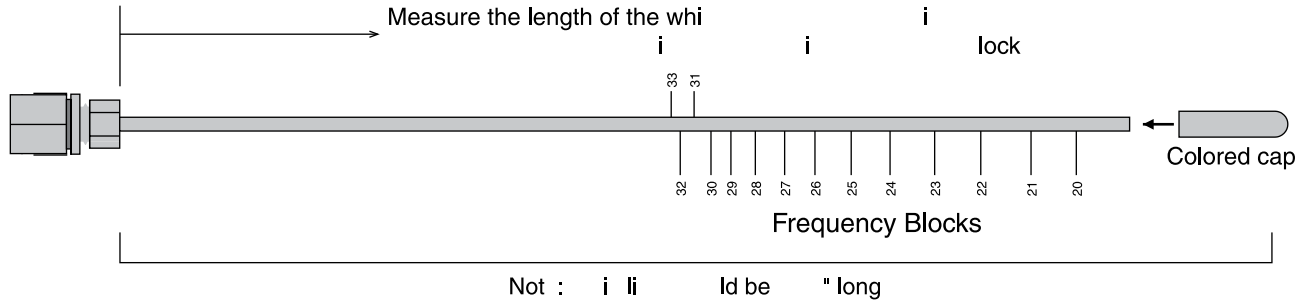

All Lectrosonic UHF transmitter antennas follow the color code specifications in the chart below to identify operating frequency block range. (The frequency block range is engraved on the outside housing for each individual transmitter.)

If a situation exists whereby the antenna is defective and the antenna cap is missing, refer to the following chart to determine the correct replacement antenna.

BLOCK	FREQUENCY RANGE	CAP COLOR	ANTENNA WHIP LENGTH
20	512.000 - 537.500	Black	4.98"
21	537.600 - 563.100	Brown	4.74"
22	563.200 - 588.700	Red	4.48"
23	588.800 - 614.300	Orange	4.24"
24	614.400 - 639.900	Yellow	4.01"
25	640.000 - 665.500	Green	3.81"
26	665.600 - 691.100	Blue	3.62"
27	691.200 - 716.700	Violet (Pink)	3.46"
28	716.800 - 742.300	Grey	3.31"
29	742.400 - 767.900	White	3.18"
30	768.000 - 793.500	Black-w/Label	3.08"
31	793.600 - 819.100	Black-w/Label	2.99"
32	819.200 - 844.700	Black-w/Label	2.92"
33	844.800 - 865.000	Black-w/Label	2.87"

NOTE: Blocks 30 through 33 are labeled with the frequency block number.



# Troubleshooting

Before going through the following chart, be sure that you have a good battery in the transmitter. It is important that you follow these steps in the sequence listed.

## Symptom

## Possible Cause

### TRANSMITTER BATTERY LED OFF

- 1) Battery is inserted backwards.
- 2) Battery is dead.

### NO TRANSMITTER MODULATION LEDS

- 1) Gain control turned all the way down.
- 2) Battery is in backwards. Check power LED.
- 3) Mic capsule is damaged or malfunctioning.
- 4) Mic cable damaged or mis-wired.

### RECEIVER RF LAMP OFF

- 1) Transmitter not turned on.
- 2) Transmitter battery is dead.
- 3) Receiver antenna missing or improperly positioned.
- 4) Transmitter and receiver not on same frequency. Check switches/display on transmitter and receiver.
- 5) Operating range is too great.
- 6) Transmitter antenna not connected

### NO SOUND (OR LOW SOUND LEVEL), RECEIVER INDICATES PROPER AUDIO MODULATION

- 1) Receiver output level set too low.
- 2) Receiver output is disconnected; cable is defective or mis-wired.
- 3) Sound system or recorder input is turned down.

### DISTORTED SOUND

- 1) Transmitter gain (audio level) is far too high. Check mod level lamps on transmitter and receiver as it is being used. (refer to pages 8/9 for details on gain adjustment)
- 2) Receiver output may be mis-matched with the sound system or recorder input. Adjust output level on receiver to the correct level for the recorder, mixer or sound system.
- 3) Excessive wind noise or breath "pops." Reposition microphone and/or use a larger windscreen.
- 4) Transmitter is not set to same frequency as receiver. Check that frequency select switches on receiver and transmitter match.

### HISS AND NOISE -- AUDIBLE DROPOUTS

- 1) Transmitter gain (audio level) far too low.
- 2) Receiver antenna missing or obstructed.
- 3) Transmitter antenna missing.
- 4) Operating range too great.

### EXCESSIVE FEEDBACK

- 1) Transmitter gain (audio level) too high. Check gain adjustment and/or reduce receiver output level.
- 2) Transmitter too close to speaker system.
- 3) Mic is too far from user's mouth.

# Specifications and Features

<b>Operating frequencies:</b>	Block 21: 537.600 - 563.100 Block 22: 563.200 - 588.700 Block 23: 588.800 - 607.900 and 614.100 - 614.300 Block 24: 614.400 - 639.900 Block 25: 640.000 - 665.500 Block 26: 665.600 - 691.100 Block 27: 691.200 - 716.700 Block 28: 716.800 - 742.300 Block 29: 742.400 - 767.900 Block 30: 768.000 - 793.500 (Export) Block 31: 793.600 - 805.600 (Export)
<b>Frequency selection:</b>	256 frequencies in 100kHz steps
<b>RF Power output:</b>	100 mW (nominal)
<b>Pilot tone:</b>	25 to 32 kHz frequency; 5kHz deviation
<b>Frequency stability:</b>	± 0.002%
<b>Deviation:</b>	± 75 kHz (max)
<b>Spurious radiation:</b>	90 dB below carrier
<b>Equivalent input noise:</b>	-120 dBV, A-weighted
<b>Input level:</b>	Nominal 2 mV to 300 mV, before limiting. Greater than 1V maximum, with limiting.
<b>Input impedance:</b>	Taps provided for 200, 4k, 40k Ohm
<b>Input compressor:</b>	Dual envelope compressor, >30 dB range
<b>Gain control range:</b>	43 dB; semi-log rotary control
<b>Modulation indicators:</b>	Dual bicolor LEDs indicate modulation of -20, -10, 0, +10 dB referenced to full modulation.
<b>Low frequency roll-off:</b>	-18 dB/octave; 35Hz to 150Hz
<b>Audio frequency response (overall system):</b>	32 Hz to 20 kHz (+/- 1dB)
<b>Controls:</b>	2 position "OFF-ON" slide switch for noiseless turn on/turn off operation. Front panel knob adjusts audio gain. Recessed control on side panel adjusts low frequency rolloff. Rotary switches on side panel adjust transmitter frequency.
<b>Audio Input Jack:</b>	Switchcraft 5 pin locking (TA5F)
<b>Antenna:</b>	Detachable, flexible wire supplied. 50 Ohm port allows connection to test equipment.
<b>Power Consumption:</b>	80mA
<b>Battery:</b>	Precision compartment auto-adjusts to accept any known alkaline 9 Volt battery.
<b>Battery Life:</b>	5 hours (alkaline); 10 hours (lithium)
<b>Weight:</b>	6.3 ozs. including battery
<b>Dimensions:</b>	3.1 x 2.4 x .75 inches

**Emission Designator:** 180KF3E

*Specifications subject to change without notice.*

## The FCC requires that the following statement be included in this manual:

This device complies with FCC radiation exposure limits as set forth for an uncontrolled environment. This device should be installed and operated so that its antenna(s) are not co-located or operating in conjunction with any other antenna or transmitter.

## Service and Repair

If your system malfunctions, you should attempt to correct or isolate the trouble before concluding that the equipment needs repair. Make sure you have followed the setup procedure and operating instructions. Check the interconnecting cables and then go through the **Troubleshooting** section in this manual.

We strongly recommend that you **do not** try to repair the equipment yourself and **do not** have the local repair shop attempt anything other than the simplest repair. If the repair is more complicated than a broken wire or loose connection, send the unit to the factory for repair and service. Don't attempt to adjust any controls inside the units. Once set at the factory, the various controls and trimmers do not drift with age or vibration and never require readjustment. **There are no adjustments inside that will make a malfunctioning unit start working.**

LECTROSONICS' Service Department is equipped and staffed to quickly repair your equipment. In warranty repairs are made at no charge in accordance with the terms of the warranty. Out-of-warranty repairs are charged at a modest flat rate plus parts and shipping. Since it takes almost as much time and effort to determine what is wrong as it does to make the repair, there is a charge for an exact quotation. We will be happy to quote approximate charges by phone for out-of-warranty repairs.

### Returning Units for Repair

For timely service, please follow the steps below:

- A. DO NOT return equipment to the factory for repair without first contacting us by email or by phone. We need to know the nature of the problem, the model number and the serial number of the equipment. We also need a phone number where you can be reached 8 A.M. to 4 P.M. (U.S. Mountain Standard Time).
- B. After receiving your request, we will issue you a return authorization number (R.A.). This number will help speed your repair through our receiving and repair departments. The return authorization number must be clearly shown on the **outside** of the shipping container.
- C. Pack the equipment carefully and ship to us, shipping costs prepaid. If necessary, we can provide you with the proper packing materials. UPS is usually the best way to ship the units. Heavy units should be "double-boxed" for safe transport.
- D. We also strongly recommend that you insure the equipment, since we cannot be responsible for loss of or damage to equipment that you ship. Of course, we insure the equipment when we ship it back to you.

#### Lectrosonics USA:

**Mailing address:**  
Lectrosonics, Inc.  
PO Box 15900  
Rio Rancho, NM 87174  
USA

**Shipping address:**  
Lectrosonics, Inc.  
581 Laser Rd.  
Rio Rancho, NM 87124  
USA

**Telephone:**  
(505) 892-4501  
(800) 821-1121 Toll-free  
(505) 892-6243 Fax

**Web:**  
www.lectrosonics.com

**E-mail:**  
sales@lectrosonics.com

#### Lectrosonics Canada:

**Mailing Address:**  
49 Spadina Avenue,  
Suite 303A  
Toronto, Ontario M5V 2J1

**Telephone:**  
(416) 596-2202  
(877) 753-2876 Toll-free  
(877-7LECTRO)  
(416) 596-6648 Fax

**E-mail:**  
Sales: colinb@lectrosonics.com  
Service: joeb@lectrosonics.com

## LIMITED ONE YEAR WARRANTY

The equipment is warranted for one year from date of purchase against defects in materials or workmanship provided it was purchased from an authorized dealer. This warranty does not cover equipment which has been abused or damaged by careless handling or shipping. This warranty does not apply to used or demonstrator equipment.

Should any defect develop, Lectrosonics, Inc. will, at our option, repair or replace any defective parts without charge for either parts or labor. If Lectrosonics, Inc. cannot correct the defect in your equipment, it will be replaced at no charge with a similar new item. Lectrosonics, Inc. will pay for the cost of returning your equipment to you.

This warranty applies only to items returned to Lectrosonics, Inc. or an authorized dealer, shipping costs prepaid, within one year from the date of purchase.

This Limited Warranty is governed by the laws of the State of New Mexico. It states the entire liability of Lectrosonics Inc. and the entire remedy of the purchaser for any breach of warranty as outlined above. NEITHER LECTROSONICS, INC. NOR ANYONE INVOLVED IN THE PRODUCTION OR DELIVERY OF THE EQUIPMENT SHALL BE LIABLE FOR ANY INDIRECT, SPECIAL, PUNITIVE, CONSEQUENTIAL, OR INCIDENTAL DAMAGES ARISING OUT OF THE USE OR INABILITY TO USE THIS EQUIPMENT EVEN IF LECTROSONICS, INC. HAS BEEN ADVISED OF THE POSSIBILITY OF SUCH DAMAGES. IN NO EVENT SHALL THE LIABILITY OF LECTROSONICS, INC. EXCEED THE PURCHASE PRICE OF ANY DEFECTIVE EQUIPMENT.

This warranty gives you specific legal rights. You may have additional legal rights which vary from state to state.

